

Cooperative Hybrid-ARQ Protocols: Unified Frameworks for Protocol Analysis

Ilmu Byun and Kwang Soon Kim

Cooperative hybrid-automatic repeat request (HARQ) protocols, which can exploit the spatial and temporal diversities, have been widely studied. The efficiency of cooperative HARQ protocols is higher than that of cooperative protocols because retransmissions are only performed when necessary. We classify cooperative HARQ protocols as three decode-and-forward-based HARQ (DF-HARQ) protocols and two amplified-and-forward-based HARQ (AF-HARQ) protocols. To compare these protocols and obtain the optimum parameters, two unified frameworks are developed for protocol analysis. Using the frameworks, we can evaluate and compare the maximum throughput and outage probabilities according to the SNR, the relay location, and the delay constraint. From the analysis we can see that the maximum achievable throughput of the DF-HARQ protocols can be much greater than that of the AF-HARQ protocols due to the incremental redundancy transmission at the relay.

Keywords: Cooperation, hybrid-ARQ, half-duplex, decode-and-forward, amplified-and-forward.

I. Introduction

In wireless mobile communication systems, various diversity techniques, such as time, frequency, and spatial diversity techniques, have been investigated to achieve spectrally efficient and reliable communications over fading channels [1]-[4]. Among them, cooperation diversity techniques, which have been widely studied, can provide spatial diversity by cooperating between users. In cooperative communication systems, distributed antennas of different users are formed as a 'virtual array' by sharing their antennas and time/frequency resource to achieve the spatial diversity.

Automatic repeat request (ARQ) is a common technique used to make a wireless link reliable. The cooperative protocols can adopt the ARQ technique by exploiting feedbacks from the relay and destinations. Since the relay or source retransmits only when the destination wants to, the efficiency of cooperative ARQ protocols is better than that of cooperative protocols without ARQ. This performance improvement of cooperative ARQ protocols has been shown in literature [5]-[7]. In [5], it was shown that the incremental relaying protocol, which can be viewed as an extension of a hybrid-ARQ (HARQ) into a cooperative context, outperforms the fixed relaying protocol in terms of its outage behavior. In [6], a dynamic decode-and-forward (DDF)-based ARQ protocol was proposed for two cooperating single-antenna terminals and a double-antenna destination. It was shown that it can achieve the optimal diversity-multiplexing (D-M) tradeoff when the number of retransmissions goes to infinity. In [7], it was shown that the DDF-based ARQ protocol can achieve the optimal D-M tradeoff in a single user relay channel when the maximum allowable number of transmissions is greater than 2. The performance of a cooperative ARQ protocol and that of a

Manuscript received Oct. 25, 2010; revised Mar 8, 2011; accepted Mar. 19, 2011.

This research was supported by the Ministry of Knowledge Economy (MKE), Rep. of Korea, under the Information Technology Research Center (ITRC) support program supervised by the National IT Industry Promotion Agency (NIPA) (NIPA-2011-C1090-1121-0007).

Ilmu Byun (phone: +82 2 2123 5861, email: dlfan@del.yonsei.ac.kr) and Kwang Soon Kim (corresponding author, email: ks.kim@yonsei.ac.kr) are with the Department of Electronic and Electrical Engineering, Yonsei University, Seoul, Rep. of Korea.

<http://dx.doi.org/10.4218/etrij.11.0110.0630>

non-cooperative ARQ protocol were also compared in [8]. It was shown that a practical cooperative ARQ protocol using a convolutional code is better than a non-cooperative ARQ protocol.

Inspired by these performance improvements, extended versions of previous cooperative protocols combined with ARQ or HARQ scheme were proposed and analyzed in [9]-[11]. In [9], three cooperative ARQ protocols, which combine the incremental relaying with the selection relaying, were proposed. Their outage behaviors were shown for a simple ARQ scheme without packet combining. In [10], cooperative HARQ protocols for multiple relays were proposed for incremental redundancy HARQ (IR-HARQ) techniques, and the upper bound of an incremental redundancy-based protocol was developed. In [11], the outage probability and the power allocation between the source and relay of a cooperative ARQ protocol were analyzed. The achievable throughput of these cooperative ARQ protocols is changed according to channel model and environment, such as the relay location, path loss, and signal-to-noise ratio (SNR). Thus, it is difficult to compare these cooperative ARQ protocols using previous analysis methods such as the outage behavior and the D-M tradeoff. In the D-M tradeoff analysis, the relay location, which is one of the dominant factors in determining performance, is not considered. Some protocol parameters, such as the initial transmission rate and the maximum number of transmissions (or the delay constraint), cannot be optimized because the D-M tradeoff provides a fundamental but only asymptotic performance. Outage behavior is also highly affected by the initial transmission rate. Thus, it is necessary to develop unified frameworks that can analyze and compare protocols considering each protocol's characteristic.

In this paper, two unified frameworks are developed. One is for DF-based cooperative HARQ (DF-HARQ) protocols (DF-HARQs), and the other is for AF-based cooperative HARQ (AF-HARQ) protocols (AF-HARQs). The DF-HARQs are classified into three types, and the AF-HARQs are classified into two types. (They are specifically described later.) The HARQ technique considered in this paper is the IR-HARQ technique due to its better performance over the Chase combining HARQ scheme [12]. In the DF-HARQs, only the IR-HARQ scheme is used. On the other hand, in the AF-HARQs, both the IR-HARQ and the Chase combining schemes are considered because the relay just forwards the amplified packet to the destination. Furthermore, the performance of each protocol is evaluated under two different power constraint scenarios. One is peak power (PP) constraint, where each terminal uses the same power for a transmission. The other is step power (SP) constraint, where the transmission power for each step is preserved. Thus, the analytical

framework provided in this paper is quite meaningful because: (i) it provides a unified approach for the analysis of cooperative HARQ protocols; (ii) it provides actual performance comparison among different protocols, which can be only done in an asymptotical manner with previous approaches; and (iii) such an analysis, considering the characteristic of each protocol, can be used to optimize the performance of each protocol according to channel and environment; and (iv) the framework can be used for adapting a protocol according to network topology.

The rest of this paper is organized as follows. In section II, the signal model and the cooperative HARQ protocols are described. In section III, the analytical frameworks are developed for the DF/AF-HARQs. The maximum achievable throughput of the cooperative HARQ protocols are obtained and compared in section IV. Finally, the concluding remark is given in section V.

II. Protocol Description and Signal Model

1. Protocol Description

In this paper, we consider a single relay network with three half-duplex terminals which consists of a source (S), a destination (D), and a relay (R). Also, we assume block fading channels, which remain constant over a block but varies independently from one block to another, and the degree of freedom of a block is L .

The cooperative HARQ protocols considered in this paper are the extensions of cooperative protocols or the cooperative ARQ protocols. We classify the DF-HARQs into three types, and the AF-HARQs into two types. In the DF-HARQs, DF1 includes the selection and incremental relaying DF protocol in [13], protocol 1 in [9], and it is similar to the MAC layer protocol in [20]. DF2 is an extended version of protocol 2 in [13]. DF3 includes the protocol with a single relay in [11] and the DDF protocol when $r_e \leq 0.5$ in [7], [14]. In the AF-HARQs, AF1 includes the selection and incremental relaying AF protocol in [5] and protocol 3 in [13]. AF2 includes protocol 3 in [13] and the NAF protocol when in $r_e \leq 0.5$ [14].

In the DF/AF-HARQs, the source and/or relay transmit a packet to the destination until the destination decodes or the number of transmissions reaches the maximum number of transmissions. The DF/AF-HARQs have two steps for an ARQ round, and the maximum number of transmissions allowed for each step is M . An ARQ round of the DF-HARQs starts from step 1, and step 2 begins if the relay decodes a packet but the destination does not. They are described as follows:

DF1. In step 1, S broadcasts a packet to D and R. In step 2, S does not transmit a packet but R transmits a packet to D.

DF2. In step 1, S transmits a packet to R but D does not receive a packet. In step 2, both S and R transmit a packet to D as a virtual array using the Alamouti code.

DF3. In step 1, S broadcasts a packet to D and R. In step 2, both S and R transmit a packet to D as a virtual array using the Alamouti code.

An ARQ round of the AF-HARQs starts from step 1. The odd (even) transmissions of the AF-HARQs are step 1 (step 2). They are described as follows:

AF1. In step 1, S broadcasts a packet to D and R. In step 2, R forwards the amplified packet to D but S does not transmit.

AF2. In step 1, S broadcasts a packet to D and R. In step 2, both S and R transmit a packet to D as a virtual array using the Alamouti code.

The destination and relay transmit ACK/NACK signals for retransmissions. The ACK/NACK signaling is assumed to be error-free for simple analysis. The resource spent for signaling ACK/NACK is also ignored since it is typically quite small compared to that used for data transmission.

2. Signal Model

At the source and relay, the b bit information is encoded using the channel code with codebook $C \in \mathcal{C}^{LN}$ of length LN over the complex numbers [15], where $N=2M$ for the DF-HARQs and $N=M$ for the AF-HARQs. The overall codeword is divided into N blocks of length L symbols, C_j , which denotes the j -th code block, $j=1, \dots, N$. Then, the transmission rate of the first block (initial transmission rate) r is given by $r=b/L$. If the destination receives the j -th codeword, it decodes using codewords $\{C_1 C_2 \dots C_j\}$.

Let $\mathbf{x}_\alpha[t] = (x_{\alpha,1}[t], \dots, x_{\alpha,L}[t])^T$ be the symbol vector of the packet transmitted from terminal α at the t -th block, where $\alpha \in \{S, R\}$. The symbol energy is normalized as $E[\mathbf{x}_\alpha^T[t] \mathbf{x}_\alpha[t]] / L = 1$ except when $\mathbf{x}_\alpha[t]$ is an amplified packet. The symbol vector $\mathbf{x}_\alpha[t]$ is changed according to protocols. For the DF-HARQs, $\mathbf{x}_S[t] = C_t$ in step 1, $\mathbf{x}_R[t] = C_t$ in step 2 of DF1, and $\mathcal{M}: C_t \rightarrow (\mathbf{x}_S[t], \mathbf{x}_R[t])$ in step 2 of DF2 and DF3, where \mathcal{M} denotes the mapping function of the Alamouti code. For the AF-HARQs, $\mathbf{x}_S[t] = C_{\lceil t/2 \rceil}$ in step 1, $\mathbf{x}_R[t] = \mathbf{y}_R[t-1]$ in step 2 of AF1, and $\mathcal{M}: (C_{\lceil t/2 \rceil}, \mathbf{y}_R[t-1]) \rightarrow (\mathbf{x}_S[t], \mathbf{x}_R[t])$ in step 2 of AF2.

Let $\mathbf{n}_\beta[t] = (n_{\beta,1}[t], \dots, n_{\beta,L}[t])^T$ be a noise vector at terminal β in which the elements are i.i.d. circular Gaussian random variable with distribution $CN(0, N_0)$, for $\beta \in \{S, R\} \setminus \alpha$. Also, let E_α be the transmit energy per symbol at terminal α and $H_{\alpha,\beta}[t] = \sqrt{g_{\alpha,\beta}} h_{\alpha,\beta}[t]$ be the channel between α and β ,

where $g_{\alpha,\beta}$ is the path loss gain and $h_{\alpha,\beta}[t]$ is a circularly Gaussian random variable with $CN(0, 1)$. Then, the received signal at the relay can be written as

$$\mathbf{y}_R[t] = \sqrt{E_S} H_{S,R}[t] \mathbf{x}_S[t] + \mathbf{n}_R[t]. \quad (1)$$

The received signals at the destination in step i , for $i=1, 2$, is given by

$$\mathbf{y}_{D,i}[t] = u_i \sqrt{E_S} H_{S,D}[t] \mathbf{x}_S[t] + v_i \sqrt{A[t] E_R} H_{R,D}[t] \mathbf{x}_R[t] + \mathbf{n}_D[t], \quad (2)$$

where $u_1=1, v_1=0, u_2=0$, and $v_2=1$ for DF1 and AF1; $u_1=0, v_1=0, u_2=1$, and $v_2=1$ for DF2; and $u_1=1, v_1=0, u_2=1$, and $v_2=1$ for DF3 and AF2. The instantaneous channel gain of the α to β link

can be respectively given by $\gamma_{\alpha,\beta}[t] = \frac{|H_{\alpha,\beta}[t]|^2 E_\alpha}{N_0}$, and the

average channel gain is given by $\gamma_{\alpha,\beta} = g_{\alpha,\beta} E_\alpha / N_0$. The amplification factor $A[t]$ is 1 for the DF-HARQs, and $\sqrt{1/(\gamma_{S,R}[t]+1)}$ for the AF-HARQs.

III. Analytical Frameworks for DF/AF-HARQs

In [15], [16], the throughput of point-to-point HARQ schemes is analyzed. The throughput is given by

$$\eta = \frac{r(1-p_{\text{out}})}{E[\tau]}, \quad (3)$$

where $E[\tau]$ denotes the average number of transmissions and p_{out} denotes the packet outage probability. Thus, the throughput of cooperative HARQ protocols can be obtained by computing $E[\tau]$ and p_{out} . In this section, two unified frameworks for the DF-HARQs and the AF-HARQs are developed to obtain the throughput.

1. Framework for DF-HARQs

In this subsection, a unified framework for the DF-HARQs is developed using state transition diagram approach. Let $S_i^i (\bar{S}_i^i)$ be the event denoting successful decoding (decoding failure) at the t -th transmission of link i , for $i=1, 2, 3$. Then, the probability of having successful decoding at the t -th transmission of link i , $q_i(t)$, is given by

$$q_i(t) = \Pr(\bar{S}_1^i, \bar{S}_2^i, \dots, \bar{S}_{i-1}^i, S_i^i). \quad (4)$$

and the probability of decoding failure with t received packets of link i is given by

$$p_i(t) = \Pr(\bar{S}_1^i, \bar{S}_2^i, \dots, \bar{S}_t^i). \quad (5)$$

Then, $q_i(t)$ can be rewritten as $q_i(t) = p_i(t-1) - p_i(t)$. The probability functions of the destination and relay in steps 1 and

2 are defined as follows. Respectively, $p_1(m)$ and $p_2(m)$ are the error probabilities of the destination and relay in step 1 when the m -th packet is received from the source. The outage probability with n received packets of the destination in step 2, while the relay successfully decodes it with m received packets in step 1, is defined as $p_3(m, n)$. Also, $q_1(m)$ and $q_2(m)$ respectively denote the probabilities of successful decoding at the destination and relay with m received packets in step 1, and $q_3(m, n)$ denotes the probability of successful decoding at the destination with m received packets in step 1 and n received packets in step 2.

Figure 1 shows the state transition diagram of the DF-HARQs. Here, all branches are labeled with the corresponding transition probabilities, multiplied by dummy variables T and U . The exponents of T and U respectively denote the number of transmissions and the rate during the transition. The states are labeled as follows: starting of one round (X_s); the state when the source transmits a packet at the m -th transmission in step 1 (A_m); the state when the relay transmits the packet at the n -th transmission in step 2 after the relay successfully decodes the received packet at the m -th transmission ($R_{m,n}$); and the end of the round when the destination decodes the packet successfully or the number of transmissions has reached M (X_e). The transition probabilities between states are listed in Table 1. In the table, $p_j(m|m-1), j=1, 2$, denotes the conditional probability of decoding failure at the m -th transmission, given that the receiver has not decoded it until the $(m-1)$ th transmission, and $p_3(m, n|m, n-1)$ denotes the conditional probability of decoding failure at the n -th transmission in step 2, given that the receiver has not decoded it until the m -th transmission in step 1 and the $(n-1)$ th transmission in step 2. As derived in Appendix A, the average number of transmissions can be calculated using the state transition diagram as

$$E[\tau] = 1 + \sum_{m=1}^{M-1} p_1(m) p_2(m) + \sum_{m=1}^M p_1(m) q_2(m) E[\tau'], \quad (6)$$

where $E[\tau'] = 1 + \sum_{n=1}^{M-1} p_3(m, n)$. Also, the outage probability of a DF-HARQ is given by

$$p_{\text{out}} = p_1(M) p_2(M) + \sum_{m=1}^M p_1(m) q_2(m) p_3(m, M). \quad (7)$$

By substituting (6) and (7) into (3), the throughput of the DF-HARQs can be obtained.

Let $J(\gamma_{\alpha,\beta}[m])$ be the mutual information between α and β at the m -th transmission, where $J(\gamma_{\alpha,\beta}[m]) = \log_2(1 + \gamma_{\alpha,\beta}[m])$ for Gaussian inputs. Then, the outage probability of the destination and relay are respectively given by

$$p_1(m) = \Pr \left\{ \sum_{s=1}^m J(u_1 \gamma_{s,D}[s]) < r \right\}, \quad (8)$$

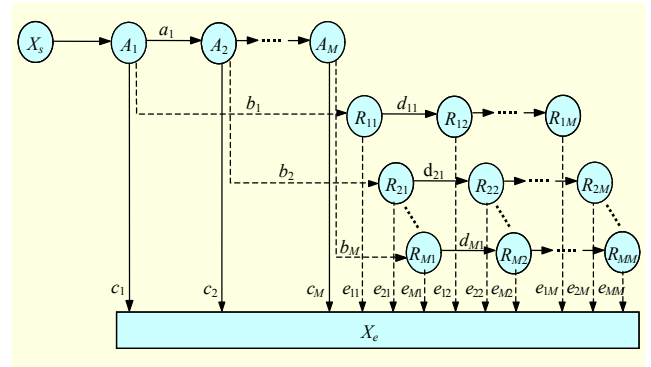

Fig. 1. State transition diagram for DF-HARQs.

Table 1. Transition probabilities for DF-HARQs.

	Transition probability
a_m	$p_1(m m-1)p_2(m m-1)T$
b_m	$p_1(m m-1)(1-p_2(m m-1))T$
c_m	$(1-p_1(m m-1))TU^r$, for $m < M$
c_M	$(1-p_1(M M-1))TU^r + p_1(M M-1)T$
$d_{m,n}$	$p_3(m, n m, n-1)T$
$e_{m,n}$	$(1-p_3(m, n m, n-1))TU^r$, for $n < M$
$e_{m,M}$	$(1-p_3(m, M m, M-1))TU^r + p_3(m, M m, M-1)T$

$$p_2(m) = \Pr \left\{ \sum_{s=1}^m J(\gamma_{s,R}[s]) < r \right\}, \quad (9)$$

$$p_3(m, n) = \Pr \left\{ \sum_{s=1}^m J(u_1 \gamma_{s,D}[s]) + \sum_{b=1}^n J(u_2 \gamma_{s,D}[b] + \gamma_{R,D}[b]) < r \right\}, \quad (10)$$

where the instantaneous SNR of the destination in step 2 is given by $\gamma_{s,D}[b] + \gamma_{R,D}[b]$ for DF2 and DF3 since the source and relay transmit an Alamouti coded signals.

The computation complexity of (9)-(11) can be reduced by the Gaussian approximation. If the sum of $J(\gamma_{\alpha,\beta}[m])$ is not small, the outage probability can be approximated using the Gaussian approximation. Let the mean of the mutual information be $\mu(\gamma_1, \dots, \gamma_k) = E[J(\sum_{i=1}^k \gamma_i[m])]$ and the variance of the mutual information be $\sigma^2(\gamma_1, \dots, \gamma_k) = V[J(\sum_{i=1}^k \gamma_i[m])]$. Then, the outage probability of the relay and destination are respectively given by

$$p_1(m) \simeq 1 - Q \left(\frac{r - m\mu(u_1 \gamma_{s,D})}{\sqrt{m\sigma^2(u_1 \gamma_{s,D})}} \right), \quad (11)$$

$$p_2(m) \simeq 1 - Q \left(\frac{r - m\mu(\gamma_{S,R})}{\sqrt{m\sigma^2(\gamma_{S,R})}} \right), \quad (12)$$

$$p_3(m, n) \simeq 1 - Q \left(\frac{r - m\mu(u_1\gamma_{S,D}) - n\mu(u_2\gamma_{S,D}, \gamma_{R,D})}{\sqrt{m\sigma^2(u_1\gamma_{S,D}) + n\sigma^2(u_2\gamma_{S,D}, \gamma_{R,D})}} \right). \quad (13)$$

For $k=1$, $\mu(\gamma_1)$ and $\sigma^2(\gamma_1)$ were calculated in [17]. For $k>1$, $\mu(\gamma_1, \dots, \gamma_k)$ and $\sigma^2(\gamma_1, \dots, \gamma_k)$ are obtained using the numerical integration.

2. Framework for AF-HARQs

To obtain the throughput and the outage probability of the AF-HARQs, a unified framework for the AF-HARQs is developed using a state transition diagram. The error probability at the destination is defined as follows. Respectively, $p_1(m)$ and $p_2(m)$ are the error probabilities of the destination at the m -th transmission in steps 1 and 2. Also, $q_1(m)$ and $q_2(m)$ respectively denote the probabilities of successful decoding of the destination at the m -th transmission in steps 1 and 2.

Figure 2 shows the state transition diagram for the AF-HARQs. In the state transition diagram, all branches are multiplied by dummy variables T and U as in the case of the DF-HARQs. The states are labeled as follows: the start of a round (X_s); the state when the source broadcasts a packet in step 1 at the m -th transmission (A_m); the state when the relay relays an amplified packet to the destination in step 2 at the m -th transmission (R_m); and the end of the round when the destination decodes successfully or the number of transmissions has reached M (X_e). The transition probabilities between states are listed in Table 2. As derived in Appendix B, the average number of transmissions can be calculated using the state transition diagram as

$$E[\tau] = \sum_{m=1}^M (2m-1)q_1(m)p_2(m-1) + 2mp_1(m)q_2(m). \quad (14)$$

Also, the outage probability of an AF-HARQ protocol is

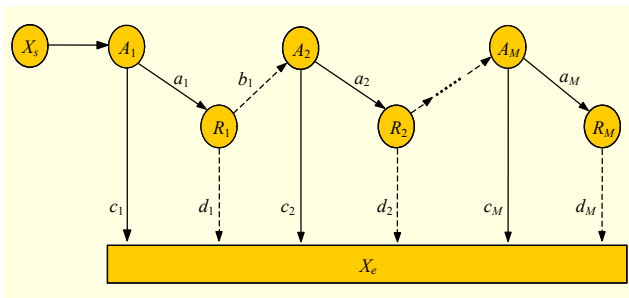

Fig. 2. State transition diagram for AF-HARQs.

Table 2. Transition probabilities for AF-HARQs.

	Transition probability
a_m	$p_1(m m-1)T$
b_m	$p_2(m m-1)T$
c_m	$(1-p_1(m m-1))TU^r$
d_m	$(1-p_2(m m-1))TU^r$, for $n < M$
d_M	$(1-p_2(M M-1))TU^r + p_2(M M-1)T$

given by

$$p_{out} = p_1(M)p_2(M). \quad (15)$$

By substituting (14) and (15) into (3), the throughput of the AF-HARQs can be obtained.

In the AF-HARQs, the source transmits a packet with additional redundancies at odd transmissions, but the relay forwards an amplified packet without additional parities at even transmissions. Thus, the outage probabilities are given by

$$p_1(m) = \Pr \left\{ \sum_{s=1}^{m-1} J(u_1\gamma_{S,D}[s-1] + u_2\gamma_{S,D}[s] + \Gamma[s]) + J(u_1\gamma_{S,D}[m]) < r \right\}, \quad (16)$$

$$p_2(m) = \Pr \left\{ \sum_{s=1}^m J(u_1\gamma_{S,D}[s-1] + u_2\gamma_{S,D}[s] + \Gamma[s]) < r \right\}, \quad (17)$$

where $\Gamma[s] = \gamma_{S,R}[s]\gamma_{R,D}[s] / (\gamma_{S,R}[s] + \gamma_{R,D}[s] + 1)$. They can be approximated using the central limit theorem as

$$p_1(m) = 1 - Q \left(\frac{r - 0.5(m-1)\mu(u_1\gamma_{S,D}, u_2\gamma_{S,D}, \Gamma) - \mu(u_1\gamma_{S,D})}{\sqrt{0.5(m-1)\sigma^2(u_1\gamma_{S,D}, u_2\gamma_{S,D}, \Gamma) + \sigma^2(u_1\gamma_{S,D})}} \right), \quad (18)$$

$$p_2(m) = 1 - Q \left(\frac{r_1 - 0.5m\mu(u_1\gamma_{S,D}, u_2\gamma_{S,D}, \Gamma)}{\sqrt{0.5m\sigma^2(u_1\gamma_{S,D}, u_2\gamma_{S,D}, \Gamma)}} \right), \quad (19)$$

Here, $\mu(u_1\gamma_{S,D}, u_2\gamma_{S,D}, \Gamma)$ and $\sigma^2(u_1\gamma_{S,D}, u_2\gamma_{S,D}, \Gamma)$ were obtained from the analysis in [18], [19] for both $u_1=1, u_2=0$ and $u_1=1, u_2=1$.

Because the two frameworks consist of the error probability of each terminal, the throughput and the outage probability of any cooperative HARQ protocol can be obtained from knowing of the error probability corresponding to a given protocol at each terminal. Thus, the proposed analysis can be used as framework for the analysis of any cooperative HARQ protocol. Also, the upper limit of protocol performance can be obtained from an information theoretic measure as well as the

actual performance from the measured or simulated error probabilities using practical modulation and coding schemes.

IV. Simulation Results

In this section, simulation is performed and compared with the analysis for the DF/AF-HARQs. The cooperative system is assumed to be a one-dimensional linear relay network for simplicity. Let the distance between the source and the destination be 1 and the distance between the source and the relay be d . The channel is assumed to be an i.i.d Rayleigh block fading. The long-term average channel gain of each link is set to be $g_{S,D}=1$ for the source-to-destination link, $g_{S,R}=d^{-\alpha}$ for the source-to-relay link, and $g_{R,D}=(1-d)^{-\alpha}$ for the relay-to-destination link, where the path-loss exponent α is set to 4. The optimum initial transmission rate is searched stepwisely with high-resolution quantization. We assume that the average transmit power of the source and relay are the same. For performance comparison, we consider the PP constraint, where the source and relay transmit packets with the same power, and the SP constraint, where the total transmission power in a step is constrained and the transmission power in step 2 is equally divided to the source and relay. For example, in DF3 with the PP constraint, E_S in step 1 is equal to E_S in step 2 and E_R in step 2. However, in DF3 with the SP constraint, the half of E_S in step 1 is equal to E_S in step 2 and E_R in step 2. In this section, DF1, DF2, and DF3 are obtained from (6) and (7) shown in subsection III.1, and AF1 and AF2 are obtained from (14) and (15) shown in subsection III.2. Also, ‘DF simul.’ and ‘AF simul.’ are obtained by Monte Carlo simulations.

1. Peak Power Constraint

In this subsection, we obtain the maximum throughput of the DF/AF-HARQs under the PP constraint. Also, E_s/N_0 denotes the long-term averaged SNR between the source and destination. Respectively, ‘DF simul.’ and ‘AF simul.’ denote the throughput obtained from the simulation of the DF-HARQs and the AF-HARQs. From Figs. 3 and 4, it is shown that the analysis for the DF-HARQs matches with the simulation results quite accurately. The analysis of the AF-HARQ protocol is also quite close to the simulation results. The small deviations in the AF-HARQ case is due to the PDF approximations in [18], [19]. Such deviation increases as the relay deviates from the center location. However, it is at most several percentages as shown in Figs. 3 and 4.

Figure 3 shows the maximum throughput of the cooperative HARQ protocols according to d when E_s/N_0 is 4 dB and 12 dB. Among the DF-HARQs, DF3 outperforms DF2 over all ranges of d and outperforms DF1 in the region of $d \leq 0.5$.

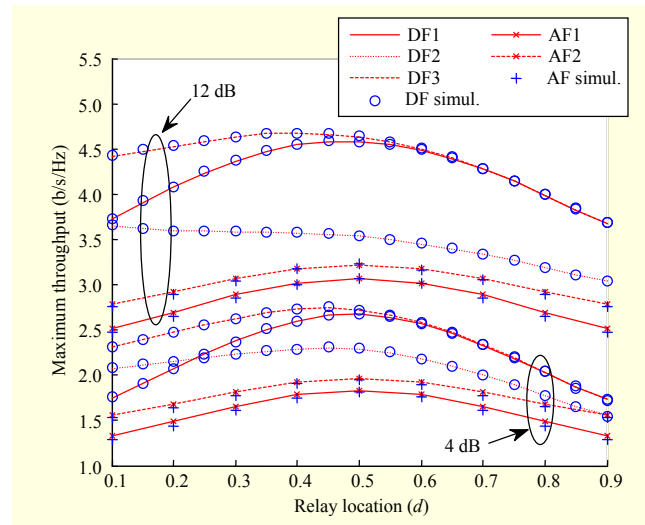

Fig. 3. Maximum throughput comparison among protocols according to d under PP constraint when $M=20$.

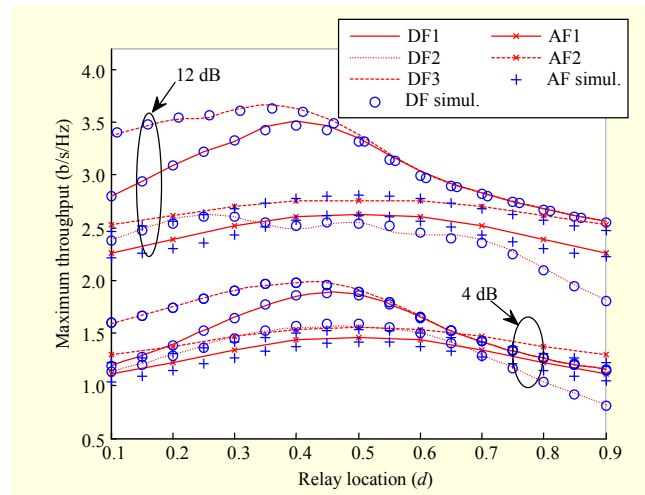

Fig. 4. Maximum throughput comparison among protocols according to d under PP constraint when $M=2$.

Where $d > 0.5$, DF1 and DF3 show similar performance in which the space-time code does not improve the performance because the source signal is much more attenuated than the relay signal. Also, it is observed that although DF1 outperforms DF2 over all ranges of d when the SNR is high (12 dB), DF1 can be worse than DF2 when the SNR is low and d is small due to the high error probability at the first transmission in DF1. Among the AF-HARQs, AF2 outperforms AF1 over all ranges of d , and the performance difference slightly increases as the relay deviates from the center region. Under the PP constraint, the average transmission energy in step 2 of DF3 and AF2 is greater than that of DF1 and AF1, which respectively results in better performance of DF3 and AF2 over DF1 and AF1. Interesting observation can be obtained by comparing the DF-HARQs with the AF-HARQs. Previously, it was believed that

the AF protocol has the same performance as the DF protocol in terms of the D-M tradeoff [14]. However, combined with the HARQ schemes, the DF-HARQs outperform the AF-HARQs over all range of SNR when $d=0.5$. The reason is that, in the AF-HARQs, the relay cannot transmit additional redundancy because the relay does not decode but just forwards the amplified packet. However, in the DF-HARQs, the relay can transmit additional redundancy. Thus, the performance of the DF-HARQs is better than that of the AF-HARQs.

Figure 4 shows the maximum throughput of the cooperative HARQ protocols according to d when $M=2$. Although the maximum throughput of each protocol decreases, the relative performance among the DF-HARQs (or the AF-HARQs) is similar in the case when the maximum number of transmissions is large ($M=20$). However, in this delay constraint case, all DF-HARQs cannot outperform the AF-HARQs since the performance gain by additional redundancy from the relay of DF-HARQs is limited. When the relay is not near the destination, DF1 and DF3 are better than the AF-HARQs. When the SNR is low (4 dB), AF2 outperforms all DF-HARQs in the region where the relay is near the destination. When the SNR is high, the AF-HARQs outperform DF2, except the region where the relay is close to the source. The value of d , which maximizes the throughput of each protocol, may also change according to the delay constraint. Although DF2, AF1, or AF2 shows its best performance when the relay is near the center, the value of d maximizing the throughput of DF1 or DF3 moves to the source as the delay constraint becomes tight.

2. Step Power Constraint

Figure 5 depicts the maximum throughput of the DF/AF-HARQs under the SP constraint. It is observed that it is different to that of the PP constraint. Among the DF-HARQs, DF1 and DF3 outperform DF2 over almost all regions of d , but the maximum throughput of DF1 is greater than that of DF3 oppositely to the PP constraint case. Similarly, the maximum throughput of AF1 is greater than that of AF2 in the region of $d \leq 0.6$. On the other hand, the maximum throughput of AF2 is greater than that of AF1 in the region of $d > 0.6$. The above observations are very interesting because they are different from the previously known results of comparing cooperative protocols without HARQ. Among the AF-HARQs, AF1 and AF2 without an HARQ scheme are, respectively, matched to LTW-AF and NAF in [14]. The D-M tradeoff of the NAF is also better than that of LTW-AF. However, AF1 can outperform AF2 in many cases. The reason is that the transmission power is divided to the source and the relays to obtain diversity gain in AF2. However, performance loss by the

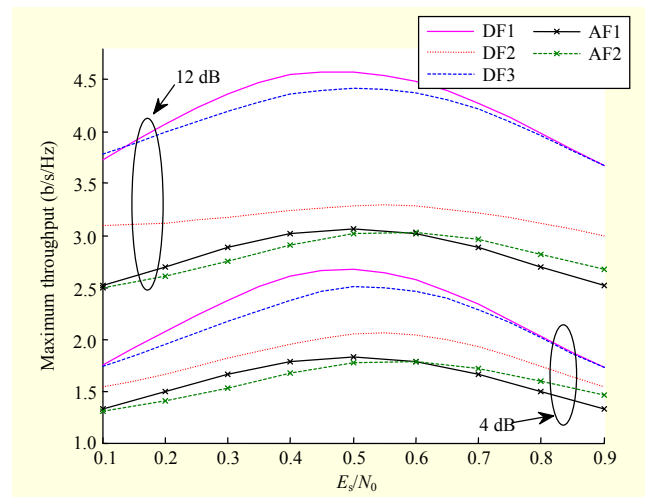

Fig. 5. Maximum throughput comparison among protocols according to d under SP constraint when $M=20$.

path-loss is greater than the diversity gain in many cases.

3. Initial Transmission Rate

In this subsection, the tradeoff between the initial transmission rate (r) and delay (M and the average delay) is shown for DF1 under the PP constraint. Although not shown explicitly, similar results and discussion can be obtained for other protocols.

To compare the throughput among various M 's, the worst-case coding-rate, $R=r/M$, is used. Figure 6 shows the throughput of DF1 according to R under the PP constraint. As can be seen in Fig. 6, when R is small, the throughput increases as R increases. However, when R is large, the throughput decreases as R increases. This is because p_{out} increases as R increases, and it becomes a dominant factor of performance degradation when R is too large. This trend of DF1 is similar to that of the IR-HARQ protocol which is shown in [16]. Additionally, it is seen that the region of R , where the throughput decreases sharply, is consistent over all values of M . Thus, for a given M , the constraint for the initial transmission rate can be set to

$$r < R^*(d, SNR)M, \quad (21)$$

where $R^*(d, SNR)$ is defined as the infimum of the worst-case coding-rate yielding zero throughput when M goes to infinity, which is a function of the relay location d and the long-term averaged SNR.

Figure 7 shows the optimum initial transmission rate r^* in terms of the throughput according to M under the PP constraint. From this figure, it is easily seen that r^* increases almost linearly as M increases. Thus, r^* for M , $r^*(M, d, SNR)$, can be obtained as

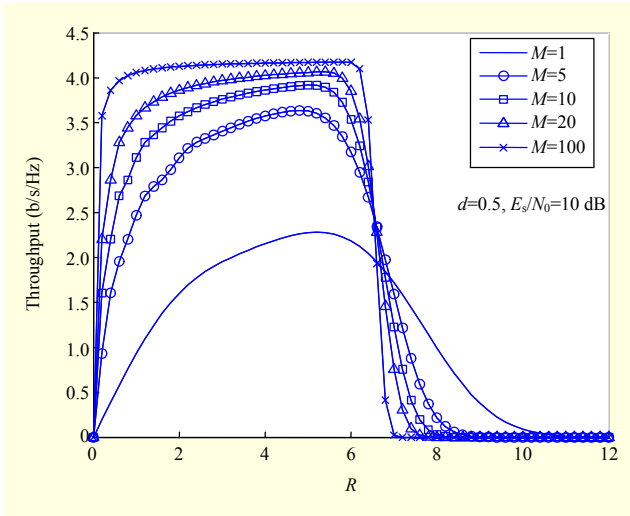

Fig. 6. Throughput of DF1 according to R under PP constraint.

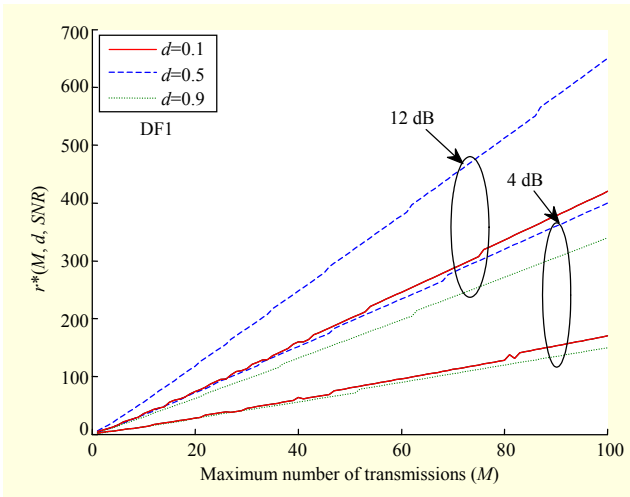

Fig. 7. Optimum initial transmission rate according to M under PP constraint.

$$r^*(M, d, SNR) = a(d, SNR)M, \quad (22)$$

where

$$a(d, SNR) = \lim_{M \rightarrow \infty} \frac{r^*(M, d, SNR)}{M}.$$

In order to apply the above optimization and tradeoff, $R^*(d, SNR)$ and $a(d, SNR)$ should be easily calculated from the knowledge of d and SNR, which remains for future work.

4. Application Example

The unified frameworks also can be used for adapting protocols. The protocol adaptation can be used for carrier sense multiple access/collision avoidance (CSMA/CA)-based cooperative MAC protocols which are used for various ad-hoc

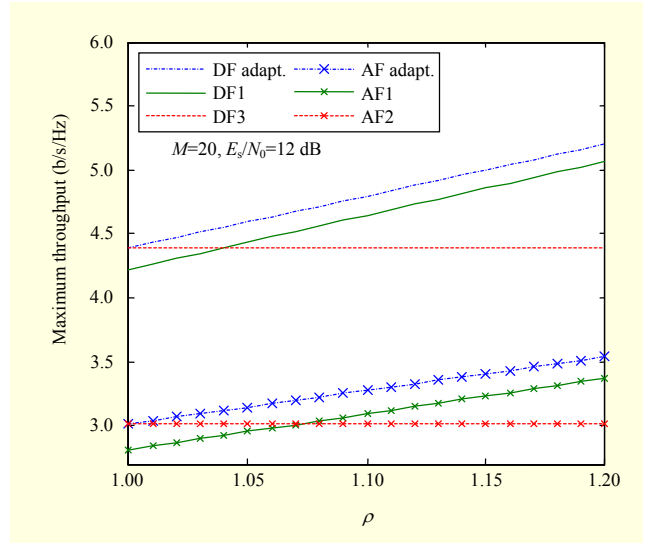

Fig. 8. Maximum throughput when DF-HARQ (AF-HARQ) is adaptively selected according to network topology.

networks such as ZigBee, UWB, and wireless local area networks (WLANs). As shown in [21], [22], cooperative MAC protocols based on the CSMA/CA decides its relay with the request-to-send (RTS) and clear-to-send (CTS) signaling, and a source-destination pair who picks up a relay at first can use the relay. Also, the protocol adaptation can be performed using the information of a protocol (for example, protocol index) included in the RTS/CTS signaling.

In WLANs, protocols can be adapted according to the network topology. For example, DF1 (AF1) can be used to improve the throughput when a source has two different data streams for two destinations. Let D_A and D_B be the destinations of a source and R_A and R_B be respectively the relays for the destinations. Then, the source transmits a packet to D_A and R_A (D_B and R_B), while R_B (R_A) transmits a packet to D_B (D_A). In the similar manner, DF2 can be used when a destination has two different data streams which are received from different sources. Figure 8 shows the maximum throughput of the DF-HARQs and AF-HARQs with a protocol adaptation under the PP constraint when $M=20$ and $E_s/N_0=12$ dB. It is obtained under the assumption that a source could have at most two destinations. Here, ρ denotes the ratio of source nodes to destination nodes in a WLAN network. If ρ is greater than 1, a part of source nodes in the network should have two destinations. In Fig. 8, ‘DF adapt.’ denotes an adaptive protocol between DF1 and DF3 and ‘AF adapt.’ denotes an adaptive protocol between AF1 and AF2. Figure 8 shows that the ‘DF (AF) adapt’ outperforms the protocols without the protocol adaptation. From the result, we can expect that the sum throughput of WLANs can be increased by the protocol adaptation according to the network topology.

V. Conclusion

In this paper, three DF-HARQs and two AF-HARQs were analyzed and compared. A unified framework was proposed for each type of cooperative HARQ protocols, which can provide actual performance evaluation with respect to channel and environment. The framework can be used for adapting a protocol according to the network topology. For example, a protocol adaptation can be used for a cooperative MAC protocol based on the CSMA/CA protocol which can be used for ZigBee, UWB, and WLANs.

By obtaining real performance comparisons among protocols from the framework, it was shown that the throughput and relative performance of the cooperative HARQ protocols varied according to the relay location, the maximum number of transmissions (or the delay constraint), the initial transmission rate, and the power constraint. Interesting observations from the analysis are as follows: (i) the maximum achievable throughput of the DF-HARQs can be much greater than that of the AF-HARQs due to the IR transmission at the relay; (ii) protocols having worse D-M tradeoff without HARQ scheme can outperform protocols having better D-M tradeoff in many cases when HARQ scheme is combined; (iii) the region maximizing the throughput of each protocol changes according to the relay location, the maximum number of transmissions, and the long-term averaged SNR; and (iv) it was shown that there is an optimum initial transmission in terms of throughput, and it is almost a linear function of the maximum number of transmissions, in which the gradient is the function of the relay location and the long-term averaged SNR. Developing a simple algorithm that evaluates the optimum initial transmission rate for a practical system remains future work.

Appendix A

From the transition probabilities, the probabilities for each state are given as $A_1=X_s$, $A_m=a_{m-1}A_{m-1}$, $R_{m,1}=b_m A_m$, $R_{m,n}=d_{m,n-1}R_{m,n-1}$, $X_e=\sum_{m=1}^M c_m A_m + \sum_{m=1}^M \sum_{n=1}^M e_{m,n} R_{m,n}$. By substituting the transition probabilities shown in Table 1 into them, we obtain

$$A_m = p_1(m-1)p_2(m-1)T^{m-1}A_1, \quad (23)$$

$$R_{m,1} = p_1(m)(p_2(m-1)-p_2(m))T^m A_1, \quad (24)$$

$$R_{m,n} = p_3(m,n-1)T^{n-1}R_{m,1}. \quad (25)$$

Using the above equations, X_e can be simplified as

$$X_e = A_1 \left(\sum_{m=1}^M q_1(m)p_2(m-1)T^m U^r X + Z \right) + \sum_{m=1}^M R_{m,1} \left(\sum_{n=1}^M q_3(m,n)T^n U^r + Z' \right), \quad (26)$$

where $Z = p_1(M)p_2(M)T^M$ and $Z' = p_3(M,M)T^M$. The transfer function of the state transition diagram of the DF-HARQs, $f(T,U) = X_e / X_s$, is then given by

$$f(T,U) = \sum_{m=1}^M q_1(m)p_2(m-1)T^m U^r + Z + \left(\sum_{m=1}^M p_1(m)q_2(m)T^m \left(\sum_{n=1}^M q_3(m,n)T^n U^r + p_3(m,M)T^M \right) \right), \quad (27)$$

where the average transmission number $E[\tau] = df(T,U)/dT|_{T=1,U=1}$ and the average transmission rate $r(1-p_{\text{out}}) = df(T,U)/dU|_{T=1,U=1}$ can be obtained by differentiating the transfer function by T and U . The packet outage probability p_{out} can be obtained from the average transmission rate.

Appendix B

In the state transition diagram of the AF-HARQs, the probabilities of each state are given as $A_1=X_s$, $A_m=b_m R_{m-1}$, $R_m=a_m A_m$, and $X_e = \sum_{m=1}^M c_m A_m + d_m R_m$. By substituting the transition probabilities shown in Table 2 into them, we obtain

$$A_m = p_1(m-1)p_2(m-1)T^{2(m-1)}A_1, \quad (28)$$

$$R_m = p_1(m)p_2(m-1)T^{2m-1}A_1. \quad (29)$$

Using the above results, X_e can be simplified as

$$X_e = \sum_{m=1}^M q_1(m)p_2(m-1)T^{2m-1}U^r X_s + p_1(m)q_2(m)T^{2m}U^r X_s. \quad (30)$$

Thus, the transfer function of the AF-HARQs, $f(T,U)=X_e/X_s$, is given by

$$f(T,U) = \sum_{m=1}^M q_1(m)p_2(m-1)T^{2m-1}U^r + p_1(m)q_2(m)T^{2m}U^r. \quad (31)$$

By differentiating the transfer function by T and U , the average transmission number $E[\tau] = df(T,U)/dT|_{T=1,U=1}$ and the average transmission rate $r(1-p_{\text{out}}) = df(T,U)/dU|_{T=1,U=1}$ can be respectively obtained. The packet outage probability p_{out} can be obtained from the average transmission rate.

References

- [1] G.J. Foschini, "Layered Space-Time Architecture for Wireless Communication in a Fading Environment When Using Multi-Element Antennas," *Bell Lab Tech. J.*, Autumn 1996, pp. 41-59.
- [2] S.M. Alamouti, "A Simple Transmit Diversity Technique for Wireless Communication," *IEEE J. Sel. Areas Commun.*, vol. 16, Oct. 1998, pp. 1451-1458.
- [3] V. Tarokh, H. Jafarkhani, and A.R. Calderbank, "Space-Time Block Codes from Orthogonal Designs," *IEEE Trans. Inform. Theory*, vol. 45, July 1999, pp. 1456-1476.
- [4] L. Zheng, D.N.C. Tse, and G.W. Wornell, "Diversity and Multiplexing: A Fundamental Tradeoff in Multiple-Antenna Channels," *IEEE Trans. Inform. Theory*, vol. 49, May 2005, pp. 1073-1096.
- [5] J.N. Laneman, D.N.C. Tse, and G. W. Wornell, "Cooperative Diversity in Wireless Networks: Efficient Protocols and Outage Behavior," *IEEE Trans. Inform. Theory*, vol. 50, Dec. 2004, pp. 3062-3080.
- [6] Y.-H. Nam et al., "Cooperation through ARQ," *Proc. IEEE Signal Proc. Adv. Wireless Commun.*, New York, NY, June 2005, pp. 1023-1027.
- [7] K. Azarian, H.E. Gamal, and P. Schniter, "On the Optimality of the ARQ-DDF Protocol," *IEEE Trans. Inform. Theory*, vol. 54, no. 4, Apr. 2008, pp. 1718-2008.
- [8] E. Zimmermann, P. Herhold, and G. Fettweis, "The Impact of Cooperation on Diversity-Exploiting Protocols," *Proc. IEEE Veh. Technol. Conf.*, vol. 49, Milan, Italy, May 2004, pp. 410-414.
- [9] G. Yu, Z. Zhang, and P. Qiu, "Cooperative ARQ in Wireless Networks: Protocols Description and Performance Analysis," *Proc. IEEE Int. Conf. Commun.*, vol. 8, Istanbul, Turkey, June 2006, pp. 3608-3614.
- [10] I. Stanojev, O. Simeone, and Y. Bar-Ness, "Performance Analysis of Collaborative Hybrid-ARQ Incremental Redundancy Protocols over Fading Channels," *Proc. IEEE Signal Proc. Adv. Wireless Commun.*, Cannes, France, July 2006, pp. 1-5.
- [11] S. Lee et al., "Cooperative Decode-and-Forward ARQ Relaying: Performance Analysis and Power Optimization," *IEEE Trans. Wireless Commun.*, vol. 9, no. 8, Aug. 2010, pp. 2632-2642.
- [12] T.E. Hunter, S. Sanayei, and A. Nersisyan, "Outage Analysis of Coded Cooperation," *IEEE Trans. Inform. Theory*, vol. 52, no. 2, Feb. 2006, pp. 375-391.
- [13] R.U. Nabar, H. Bölcskei, and F.W. Kneubühler, "Fading Relay Channels: Performance Limits and Space Time Signal Design," *IEEE Trans. J. Sel. Areas Commun.*, Aug. 2004, pp. 1099-1109.
- [14] K. Azarian, H. El Gamal, and P. Schniter, "On the Achievable diversity-Multiplexing Tradeoff in Half-Duplex Cooperative Channels," *IEEE Trans. Inform. Theory*, Dec. 2005, pp. 4152-4172.
- [15] G. Caire and D. Tuninetti, "The Throughput of Hybrid ARQ Protocols for the Gaussian Collision Channel," *IEEE Trans. Inform. Theory*, vol. 47, no. 5, July 2001, pp. 1971-1988.
- [16] S. Sesia, G. Caire, and G. Vivier, "Incremental Redundancy Hybrid ARQ Schemes Based on LDPC Codes," *IEEE Trans. Commun.*, vol. 52, no. 8, Aug. 2004, pp. 1311-1321.
- [17] W. Peng, "Performance of Hybrid-ARQ in Block-Fading Channels: A Fixed Outage Probability Analysis," *IEEE Trans. Commun.*, vol. 58, no. 4, Apr. 2008, pp. 1129-1141.
- [18] P.A. Anghel and M. Kaveh, "Exact Symbol Error Probability of a Cooperative Network in a Rayleigh-Fading Environment," *IEEE Trans. Wireless Commun.*, vol. 3, no. 5, Sept. 2004.
- [19] M.O. Hasna and M.S. Alouini, "A Performance Study of Dual-Hop Transmissions with Fixed Gain Relays," *IEEE Trans. Wireless Commun.*, vol. 3, no. 6, Nov. 2004, pp. 1963-1968.
- [20] C. Nie et al., "CoopMAX: A Cooperative MAC with Randomized Distributed Space-Time Coding for an IEEE 802.16 Network," *Proc. IEEE Conf. Int. Conf. Commun.*, Dresden, Germany, June 2009, pp. 1-6.
- [21] P. Liu et al., "CoopMAC: A Cooperative MAC for Wireless LANs," *IEEE J. Sel. Area Commun.*, vol. 25, no. 2, Feb. 2007, pp. 340-354.
- [22] H. Shan, W. Zhuang, and Z. Wang, "Distributed Cooperative MAC for Multihop Wireless Networks," *IEEE Commun. Mag.*, vol. 47, no. 2, Feb. 2009, pp. 126-133.



and hybrid networks.

Ilmu Byun received the BS and MS in electrical and electronic engineering from Yonsei University, Seoul, Rep. of Korea, in 2005 and 2007, respectively. Since 2007, he has been pursuing the PhD at Yonsei University. His current research interests include rate-compatible channel codes, ad-hoc networks,



Kwang Soon Kim received the BS (summa cum laude), MSE, and PhD in electrical engineering from Korea Advanced Institute of Science and Technology (KAIST), Daejeon, Rep. of Korea, in February 1994, February 1996, and February 1999, respectively. From March 1999 to March 2000, he was with the Department of Electrical and Computer Engineering, University of California at San Diego, CA, USA, as a postdoctoral researcher. From April 2000 to February 2004, he was with the Mobile Telecommunication Research Laboratory, ETRI, Daejeon, Rep. of Korea, as a senior member of research staff. Since March 2004, he has been with the Department of Electrical and Electronic Engineering, Yonsei University, Seoul, Rep. of Korea, where he is now is an associate professor. He was a recipient of the postdoctoral fellowship from Korea Science and Engineering Foundation (KOSEF) in 1999.

He received the Outstanding Researcher Award from ETRI in 2002 and the Jack Neubauer Memorial Award (Best System Paper Award, IEEE Transactions on Vehicular Technology) from IEEE Vehicular Technology Society in 2008. His research interests include communication theory, channel coding, multiuser/multicell MIMO, capacity and cross-layer optimization of wireless networks, and cross-layer optimization of heterogeneous cellular networks.